



CG37 Hardware Design

GNSS Module Series

Version: V1.0

Date: 2023-03-14

Notice

Some features of the product and its accessories described herein rely on the software installed, capacities and settings of local network, and therefore may not be activated or may be limited by local network operators or network service providers. Thus, the descriptions herein may not exactly match the product or its accessories which you purchase. Technoration India Pvt. Ltd. reserves the right to change or modify any information or specifications contained in this manual without prior notice and without any liability.

Copyright

This document contains proprietary technical information which is the property of Technoration India Pvt. Ltd. copying of this document and giving it to others and the using or communication of the contents thereof, are forbidden without express authority. Offenders are liable to the payment of damages. All rights reserved in the event of grant of patent or the registration of a utility model or design. All specification supplied herein are subject to change without notice at any time.

DISCLAIMER

ALL CONTENTS OF THIS MANUAL ARE PROVIDED "AS IS". EXCEPT AS REQUIRED BY APPLICABLE LAWS, NO WARRANTIES OF ANY KIND, EITHER EXPRESS OR IMPLIED, INCLUDING BUT NOT LIMITED TO, THE IMPLIED WARRANTIES OF MERCHANTABILITY AND FITNESS FOR A PARTICULAR PURPOSE, ARE MADE IN RELATION TO THE ACCURACY, RELIABILITY OR CONTENTS OF THIS MANUAL. TO THE MAXIMUM EXTENT PERMITTED BY APPLICABLE LAW, IN NO EVENT SHALL TECHNORATION INDIA PVT. LTD. BE LIABLE FOR ANY SPECIAL, INCIDENTAL, INDIRECT, OR CONSEQUENTIAL DAMAGES, OR LOSS OF PROFITS, BUSINESS, REVENUE, DATA, GOODWILL SAVINGS OR ANTICIPATED SAVINGS REGARDLESS OF WHETHER SUCH LOSSES ARE FORSEEABLE OR NOT.

Version History

Date	Version	Modify records	Author
2023-03-14	V1.0	First release	Sanjeet

Content

1. Introduction.....	5
2. CG37 Overview	5
2.1 CG37 Functional Diagram	6
2.2 GNSS Performance	7
2.3 General features	8
3. Package Information.....	10
3.1 Pin out Diagram.....	10
3.2 Pin Description	10
3.3 Package Dimensions	11
3.4 CG37 Recommended PCB Decal.....	12
4. Application Interface	14
4.1 Power Management.....	14
4.1.1 Power Input.....	14
4.1.2 Starting CG37	14
4.1.3 Verification of CG37 Start.....	14
4.1.4 Power Saving Modes	14
4.1.5 Operating Mode	15
4.2 UART Interface.....	18
4.3 TIMEMARK Output.....	18
4.4 AGPS and DGPS.....	18
4.5 GNSS Antenna.....	19
4.5.1 Antenna specification	19
4.5.2 Application Notes	21
5. Electrical, Reliability and Radio Characteristics	28
5.1 Absolute Maximum Ratings	28
5.2 Recommended Operating Conditions	28
5.3 Electro-Static Discharge	29
6. Manufacturing.....	31
6.1 Top and Bottom View of CG37	31
6.2 Assembly and Soldering	31
6.3 Moisture sensitivity	32
6.4 ESD handling precautions	33
6.5 Shipment	34
7. Reference Design.....	35

8. Appendix	35
A. Related Documents	35
B. Terms and Abbreviations	35

1. Introduction

This document describes the hardware interface of the TECHNORATION module CG37 which can be used as a stand-alone GNSS or A-GPS (Assisted Global Positioning System) receiver with a patch antenna on top of the module. As a wide range of applications can be integrated in CG37, all functional components of CG37 are described in great detail.

2. CG37 Overview

CG37 is GNSS module with built-in LNA and Patch Antenna (18.5*18.5*4.0mm), don't need an extra antenna and external LNA. CG37 can track as low as -165dBm signal level. CG37 has excellent low power consumption characteristic (acquisition 25mA, tracking 22mA). CG37 supports various location and navigation applications, including autonomous GPS/Galileo/Glonass/BD2/QZSS.

Key Features

- GNSS receiver, supports QZSS
- 33 tracking/99 acquisition-channel, up to 210 PRN channels
- Small footprint: 16.0x16.0 x6.2mm, 13-pin LCC package
- Patch dimensions: 18.5x18.5 x 4.0mm
- 12 multi-tone active interference cancellers and jamming elimination
- Indoor and outdoor multi-path detection and compensation
- Max NMEA update rate up to 10 Hz
- Advanced software features
 1. PPS sync NMEA
 2. Supports logger function
 3. Supports active interference cancellation (AIC)

- Pulse-per-second (PPS) GNSS time reference
 1. Adjustable duty cycle
 2. Typical accuracy: $\pm 10\text{ns}$
- Interface
 - UART
- Operating temperature: $-40 \sim +85^{\circ}\text{C}$
- Accuracy $< 2.5\text{m CEP}@-130\text{dBm}$
- ROHS compliant

The module provides complete signal processing from antenna input to host port in either NMEA messages. The module requires 2.8V~4.3V power supply. The host port is configurable to UART. Host data and I/O signal levels are 2.85V CMOS compatible.

2.1 CG37 Functional Diagram

The following figure shows a functional diagram of the CG37 and illustrates the mainly functional parts:

- The GNSS chip
- SAW filter
- LNA
- The antenna interface
- The communication interface
- The control signals

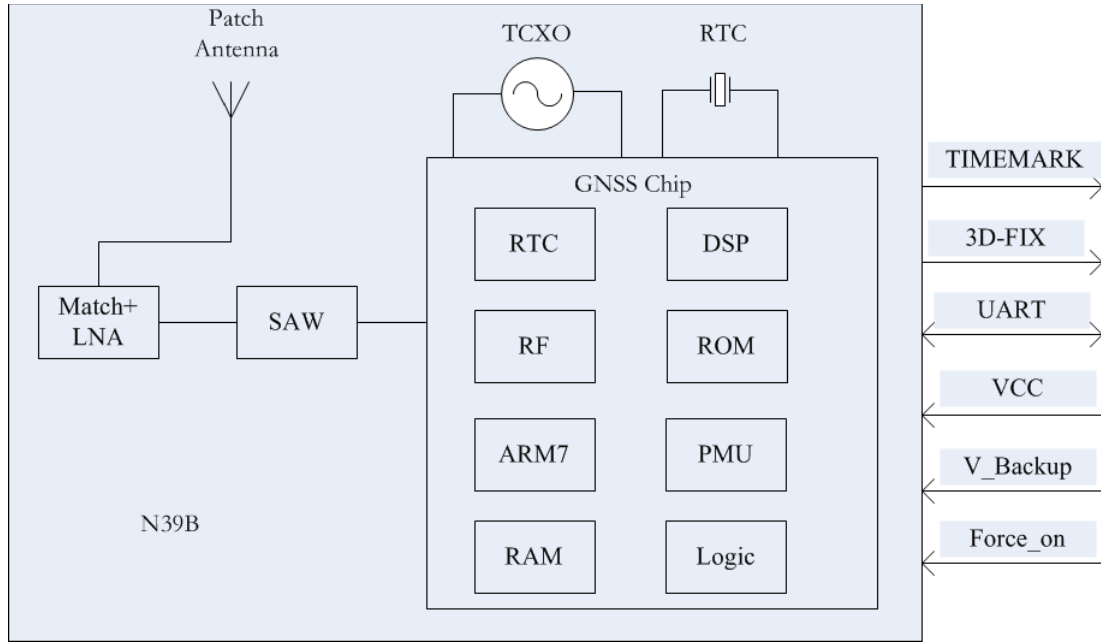

Figure 1 CG37 functional diagram

2.2 GNSS Performance

Table 1 GNSS performance

Parameter	Description	Performance			
		Min	Type	Max	Unit
Horizontal Position Accuracy ⁽¹⁾	Autonomous		<2.5		m
	Without Aid		0.1		m/s
Velocity Accuracy ⁽²⁾	DGPS		0.05		m/s
	Without Aid		0.1		m/s ²
Acceleration Accuracy	DGPS		0.05		m/s ²
	Timing Accuracy		10		ns
Dynamic Performance	Maximum Altitude			18000	m
	Maximum Velocity			515	m/s
	Maximum Acceleration			4	G

Time To First Fix ⁽³⁾ without EASY™	Hot start		<1		s
	Warm start		30		s
	Cold start		32		s
TTFF with EASY™	Hot start		<1		s
	Warm start		5		s
	Cold start		15		s
Sensitivity ⁽³⁾	Autonomous acquisition(cold start)		-148		dBm
	Re-acquisition		-160		dBm
	Tracking		-165		dBm
Receiver	Channels		33 tracking/99 acquisition		
	Update rate		1	10	Hz
	Tracking L1, CA Code				
	Protocol support NMEA,PMTK				
Power consumption ⁽⁴⁾	Acquisition		25		mA
	Continuous tracking		22		mA
	Sleep current		340		uA
	Backup current		14		uA

(1) 50% 24hr static, -130dBm

(2) 50% at 30m/s

(3) GNSS signal level: -130dBm

(4) Single Power supply 3.3V@-130dBm

2.3 General features

Table 2 General features

Parameters	Value
Supply voltage VCC	+2.8V~4.3V
Supply voltage ripple VCC	54 mV(RMS) max @ f = 0~3MHz 15 mV(RMS) max @ f > 3 MHz

Power consumption(acquisition)	25mA type. @ VCC=3.3 V –130dBm	
Power consumption(sleep)	340uA type. @ VCC=3.3 V	
Storage temperature	-40°C~+125°C	
Operating temperature	-40°C~+85°C (note 1)	
I/O signal levels	V _{IL}	-0.3V~0.8V
	V _{IH}	2.0V~3.6V
	V _{OL}	-0.3V~0.4V
	V _{OH}	2.4V~3.1V
I/O output sink/source capability	+/- 3mA max	
I/O input leakage	+/- 10uA max	
Host port	UART0	
Serial port protocol (UART)	NMEA; 8 bits, no parity, 1 stop bit; 115200 bps	
TIMEMARK output (1PPS)	1 pulse per second, synchronized at rising edge, pulse length100ms	

Note 1: Operation in the temperature range –40°C~ –30°C is allowed but Time-to-First-Fix performance and tracking sensitivity may be degraded.

3. Package Information

3.1 Pin out Diagram

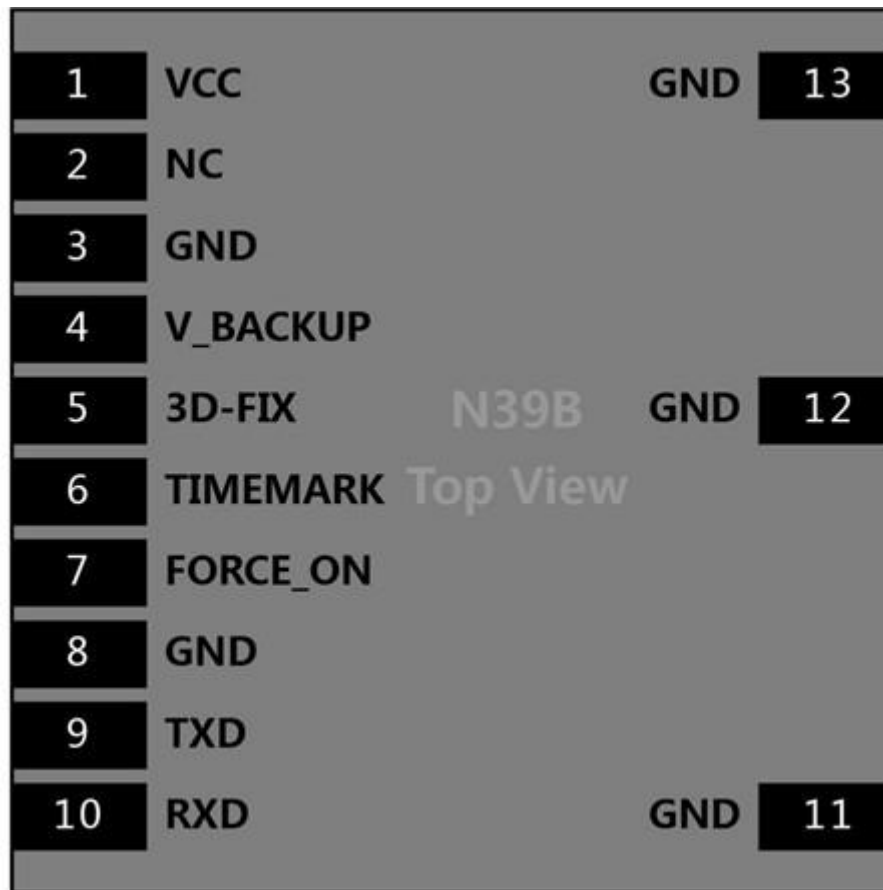

Figure 2 CG37 pin out diagram (Top view)

3.2 Pin Description

Table 3 Pin description

Pin name	Pin number	I/O	Description	Comment
Power supply				
VCC	1	I	Main power input, Typical: 3.3V. The VCC ripple must be controlled under	Add a 4.7uF capacitor to this pin for decoupling.

VCC_BACK UP	4	I	54mVpp The backup battery input power supply for RTC 2.0V~4.3V, Typical 3.0V	If unused, keep open.
GND	3,8,11,12,13		Ground	
Host port interface				
TXD0	9	O	Serial data output of NMEA	
RXD0	10	I	Serial data input for firmware update	
GPIOS				
3D-FIX	5	O	3D-fix indicator	If unused, keep open Keep this pin open or pulled low before Entering into backup mode. If unused, keep open
TIMEMARK	6	O	1PPS Time Mark Output 2.85V CMOS Level ,timing pulse related to receiver time	
FORCE_ON	7	I	Logic high will Force module to be waked up from backup mode	
Other interface				
NC	2		Not Connected	

3.3 Package Dimensions

Following figure shows the Mechanical dimensions of CG37 (top view, side view and bottom view).

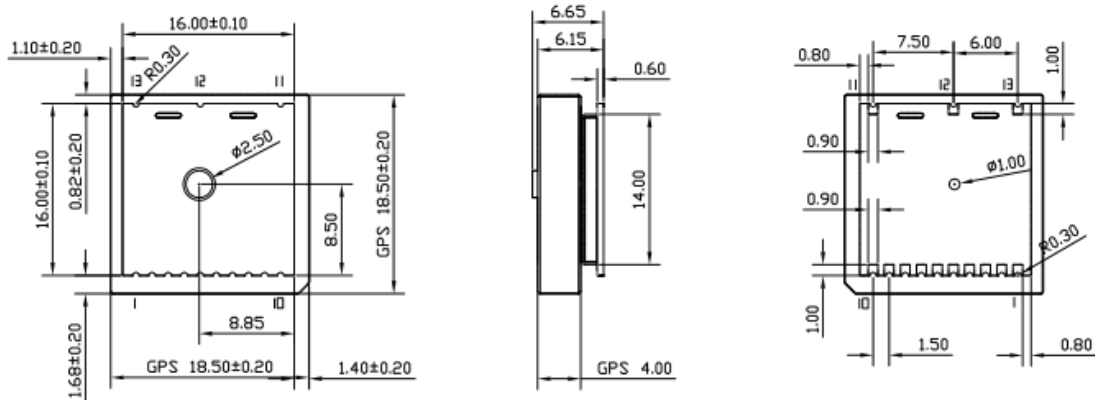

Figure 3 CG37 mechanical dimensions (Unit: mm)

3.4 CG37 Recommended PCB Decal

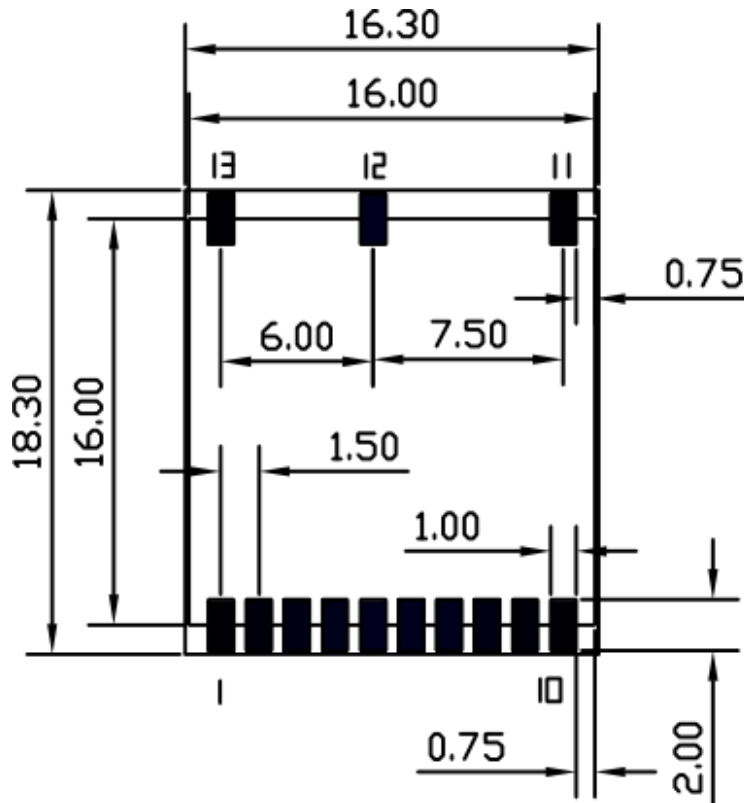

Figure 4 Recommended PCB decal (top view) (Unit: mm)

4. Application Interface

4.1 Power Management

4.1.1 Power Input

The power supply range of CG37 is from 2.8V to 4.3V. The power supply should be able to provide sufficient current up to 100mA.

The power supply range of V_BACKUP is from 2.0V to 4.3V, typical 3.0V, suggesting customer keep the V_BACKUP supply active all the time, module will perform a quick start every time it is power-on.

4.1.2 Starting CG37

When power is first applied, CG37 goes into operation mode.

4.1.3 Verification of CG37 Start

System activity indication depends upon the chosen serial interface: When it is activated, CG37 will output messages at the selected UART speed and message types.

4.1.4 Power Saving Modes

CG37 supports operating modes for reduced average power consumption like standby mode, backup mode and periodic mode.

- **Sleep mode:** In this mode the receiver stays at full on power state. When this mode that can be wake up by the host sends the command through the communication interface.
- **Backup mode:** In this mode the CG37 must be supplied by the V_BACKUP pin and the VCC power should be cut off. The module could not achieve this mode through PMTK commands.

CG37 provides very low leakage battery backup memory, which contains all the necessary GNSS information for quick start up and a small amount of user configuration variables. It needs a 3V power supply for V_BACKUP pin.

- **Periodic mode:** In this mode the CG37 enters tracking and sleep or Backup mode according to the interval configured.

4.1.5 Operating Mode

Table 4 Power supply and clock state according to operation mode

Mode	VCC	V_BACKUP	Internal LDO	Main clock	RTC clock
Full on	on	on	on	on	on
Sleep	on	on	off	off	on
Backup	off	on	off	off	on

Full on Mode

The module will enter full on mode after first power up with factory configuration settings. Power consumption will vary depending on the amount of satellite acquisitions and number of satellites in track.

Sleep Mode

Sleep mode means a low quiescent (340uA type.) power state, non-volatile RTC, and backup RAM block is powered on. Other internal blocks like digital baseband and RF are internally powered off. The power supply input VCC shall be kept active all the time, even during sleep mode.

Entering into sleep mode is sent PMTK command through the communication interface by host side.

Waking up from sleep mode is sent any byte through the communication interface by host side.

Backup Mode

This connects to the backup power of the module. Power source (such as battery or cap) connected to V_BACKUP pin will help the chipset in keeping its internal RTC running when the VCC power source is turned off. The voltage should be kept between 2.0~4.3V, Typical 3.0V.

The V_BACKUP power should be kept active all the time, the module will perform a quick start every time it is power-on.

Entering into sleep mode is sent PMTK command and keep FORCE_ON low. The only way to wake up the module is pulling the FORCE_ON high.

Periodic Mode

In this mode the CG37 enters tracking and sleep or Backup mode according to the interval configured by users in the commands.

Table 5 PMTK225 Command Format

Format: \$PMTK225,<Type>,<Run_time>,<Sleep_time>,<2nd_run_time>,<2nd_sleep_time>*<checksum><CR><LF>		
Parameter	Format	Description
Type	Decimal	0:full on mode 1:Periodic Backup Mode 2:Periodic Sleep Mode 4: Backup Mode
Run_time	Decimal	Full on mode period
Sleep_time	Decimal	Sleep/Backup mode period

2nd_run_time	Decimal	Full on mode period for 2nd acquisition when module acquisition fails during the Run_time
2nd_sleep_time	Decimal	Sleep/Backup mode period for 2nd sleep when module acquisition fails during the Run_time
Checksum	Hexadecimal	Hexadecimal checksum

The average current value can be calculated by the following formula:

$$I_{\text{periodic}} = (I_{\text{tracking}} * T_{\text{run_time}} + I_{\text{sleep/backup}} * T_{\text{sleep_time}}) / (T_{\text{run_time}} + T_{\text{sleep_time}})$$

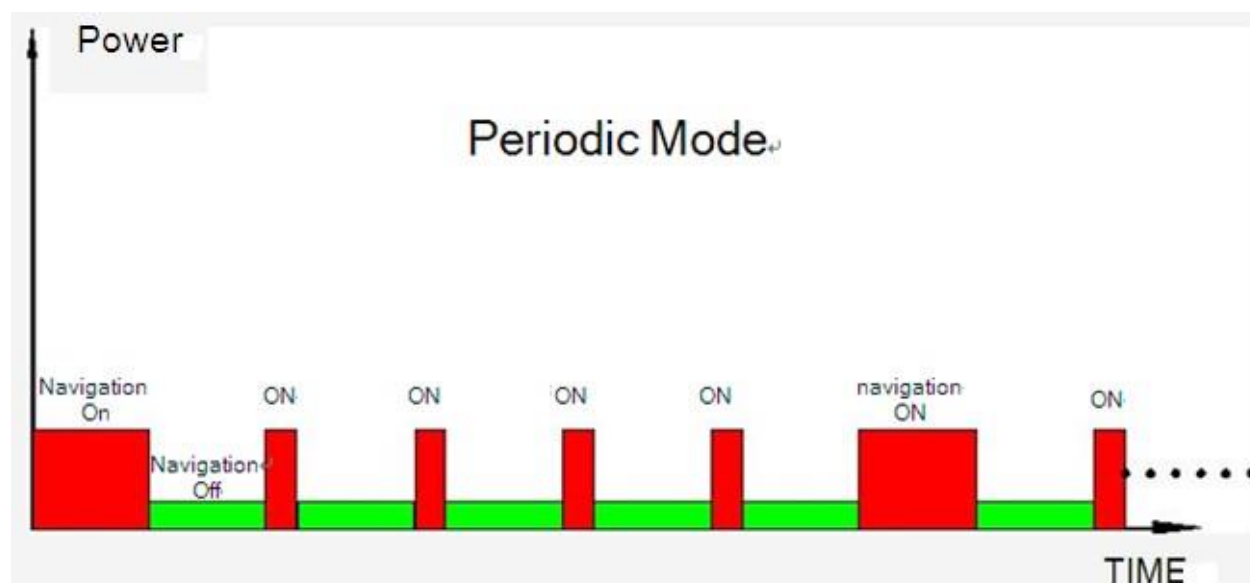

Figure 5 Periodic Mode

4.2 UART Interface

The interface for serial communication of CG37 is UART. The UART is as NEMA output and PMTK command input. The receiver (RXD0) and transmitter (TXD0) side of every port contains a 16-byte FIFO. UART can provide the developers signal or message outputs. The baud rate is 115200 bps.

4.3 TIMEMARK Output

The TIMEMARK pin outputs one pulse-per-second (1PPS) pulse signal for precise timing purposes. The TIMEMARK signal can be provided through designated output pin for many external applications.

This pulse is not only limited to be active every second but also allowed to set the required duration, frequency, and active high/low by programming user-defined settings.

4.4 AGPS and DGPS

A-GPS is the meaning of Assisted GPS, which is a system that can improve the startup performance and time-to-first-fix (TTFF) of a GNSS satellite-based positioning under certain conditions. CG37

module supports EPO file, EASY™.

4.5 GNSS Antenna

4.5.1 Antenna specification

CG37 has integrated a internal GNSS antenna, which is a passive patch antenna. Patch antenna size is 18.5*18.5*4.0mm.The customer does not need tuning the GNSS antenna additionally.

The specifications of the integrated GNSS antenna are presented as following table:

Table 6 Antenna Specifications

Parameter	Specification	
Passive Antenna Recommendations	Frequency range	GPS:1575.42±3MHz BD:1561±3 MHz
	Band Width	10MHz
	Frequency Temperature Coefficient	0±20ppm/°C
	Polarization	RHCP
	Gain at Zenith	2.5dBic
	VSWR	<2dB
	Impedance	50 Ω

The test result of the antenna is shown as the following figure. The GNSS antenna provides good radiation efficiency, right hand circular polarization and optimized radiation pattern.

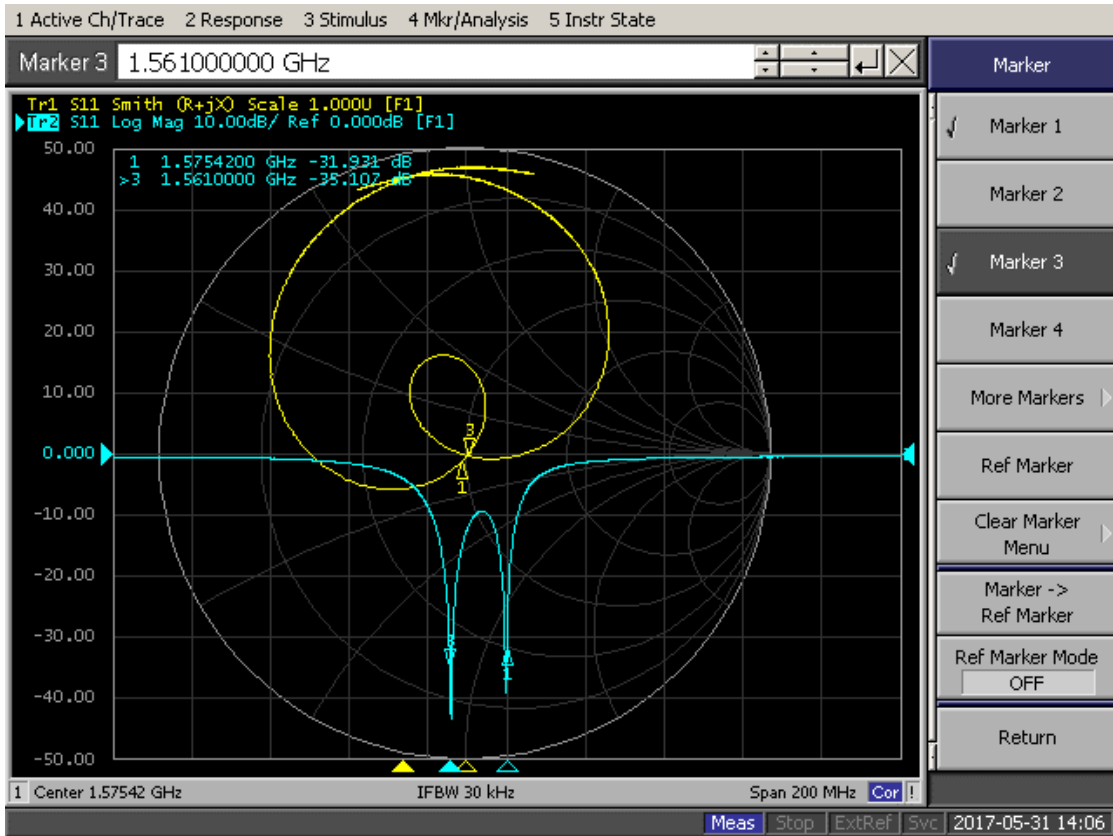

Figure 7 Patch Antenna Test Result with Ground Plane 50mm*50mm

4.5.2 Application Notes

The GNSS Patch antenna consists of a radiating patch on one side of a dielectric material substrate backed by a ground plane on the other side.

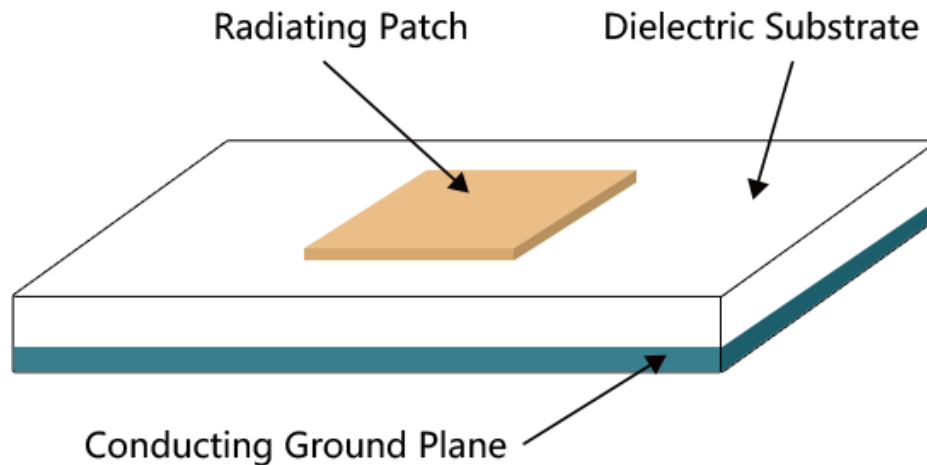

Figure 8 GNSS Patch antenna on the Main Board

Customer can refer to the following rules, when the CG37 is integrated into the main Board:

1. The most important rule is to ensure the antenna towards the sky.
2. The antenna should not be covered by any metalized enclosure or metal device.
3. The antenna must be placed far away from memory, camera, LCM, TP, DCDC etc. high-power highheat area.
4. The height of device around the module, should not exceed the antenna. The components which height is more than 6.4mm, must keep more than 10mm distance between module.

5. Electrical, Reliability and Radio Characteristics

5.1 Absolute Maximum Ratings

The absolute maximum ratings stated in Table 7 are stress ratings under non-operating conditions. Stresses beyond any of these limits will cause permanent damage to CG37.

Table 7 Absolute maximum rating

Parameter	Min	Max	Unit
VCC		4.3	V
Input Power at GNSS_ANT		-12	dBm
V_BACKUP		4.3	V
I/O pin voltage		3.6	V
Storage temperature	-45	+125	°C
Operating Temperature	-40	+85	°C

5.2 Recommended Operating Conditions

Table 8 CG37 operating conditions

Parameter	Symbol	Min	Type	Max	Unit
Operating temperature range		-40	+25	+85	°C
Main supply voltage	VCC	2.8	3.3	4.3	V
Backup battery voltage	V_BACKUP	2.0	3	4.3	V

Table 9 CG37 standard IO feature

Parameter	Symbol	Min	Type	Max	Unit
Low level output voltage Test conditions $I_{OL} = 2\text{mA}$ and 4.0mA	V_{OL}	-0.3		0.40	V
High level output voltage Test conditions $I_{OL} = 2\text{mA}$ and 4.0mA	V_{OH}	2.4	2.8	3.1	V
Low level input voltage	V_{IL}	-0.3		0.8	V
High level input voltage	V_{IH}	2.0		3.6	V
Input Pull-up resistance	R_{PU}	40		190	$K\Omega$
Input Pull-down resistance	R_{PD}	40		190	$K\Omega$
Input capacitance	C_{IN}		5		pF
Load capacitance	C_{load}			8	pF
Tri-state leakage current	I_{OZ}	-10		10	μA

5.3 Electro-Static Discharge

The GNSS engine is not protected against Electrostatic Discharge (ESD) in general. Therefore, it is subject to ESD handling precautions that typically apply to ESD sensitive components. Proper ESD handling and packaging procedures must be applied throughout the processing, handling and operation of any application using a CG37 module. The ESD test results are shown in the following table.

Table 10 The ESD characteristics (Temperature:25°C, Humidity:45%)

Pin	Contact discharge	Air discharge
VCC	$\pm 5\text{KV}$	$\pm 10\text{KV}$
GNSS_ANT	$\pm 5\text{KV}$	$\pm 10\text{KV}$
V_BACKUP	$\pm 5\text{KV}$	$\pm 10\text{KV}$
GND	$\pm 5\text{KV}$	$\pm 10\text{KV}$

RXD, TXD	±4KV	±8KV
FORCE_ON	±4KV	±8KV
TIMEMARK	±4KV	±8KV
3D-FIX	±4KV	±8KV

6. Manufacturing

6.1 Top and Bottom View of CG37

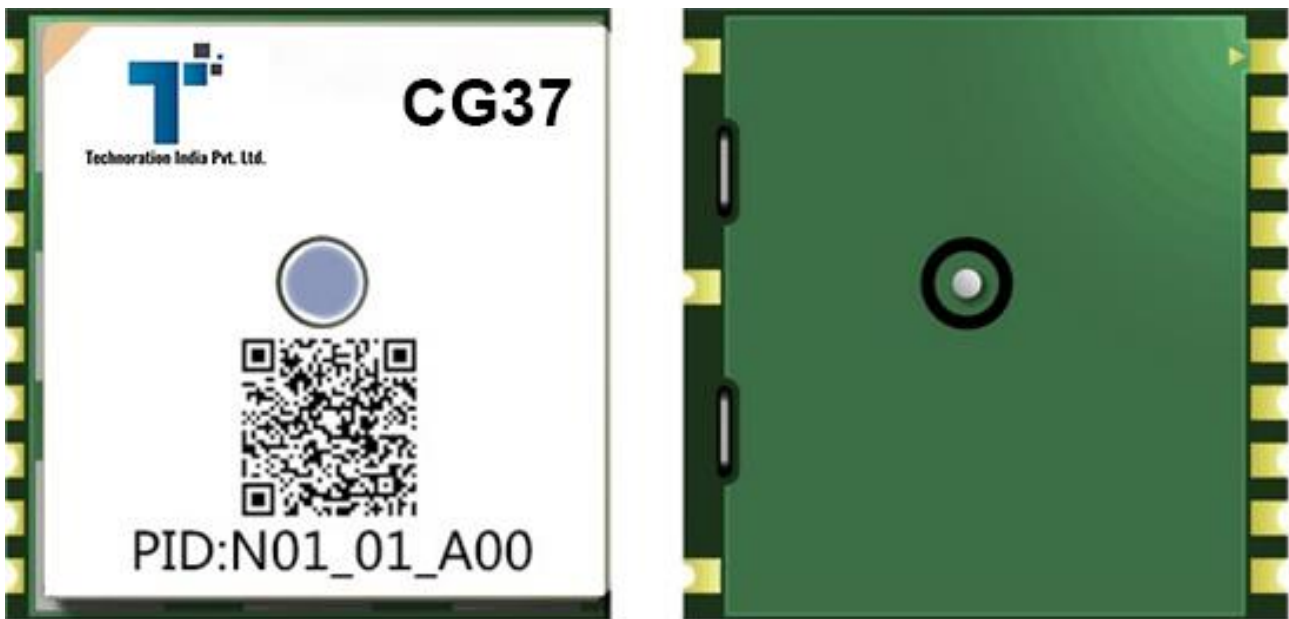

Figure 9 Top and Bottom View of CG37

6.2 Assembly and Soldering

The CG37 module is intended for SMT assembly and soldering in a Pb-free reflow process on the top side of the PCB. Suggested solder paste stencil height is 150um minimum to ensure sufficient solder volume. If required paste mask pad openings can be increased to ensure proper soldering and solder wetting over pads.

The following figure is the Ramp-Soak-Spike Reflow Profile of CG37:

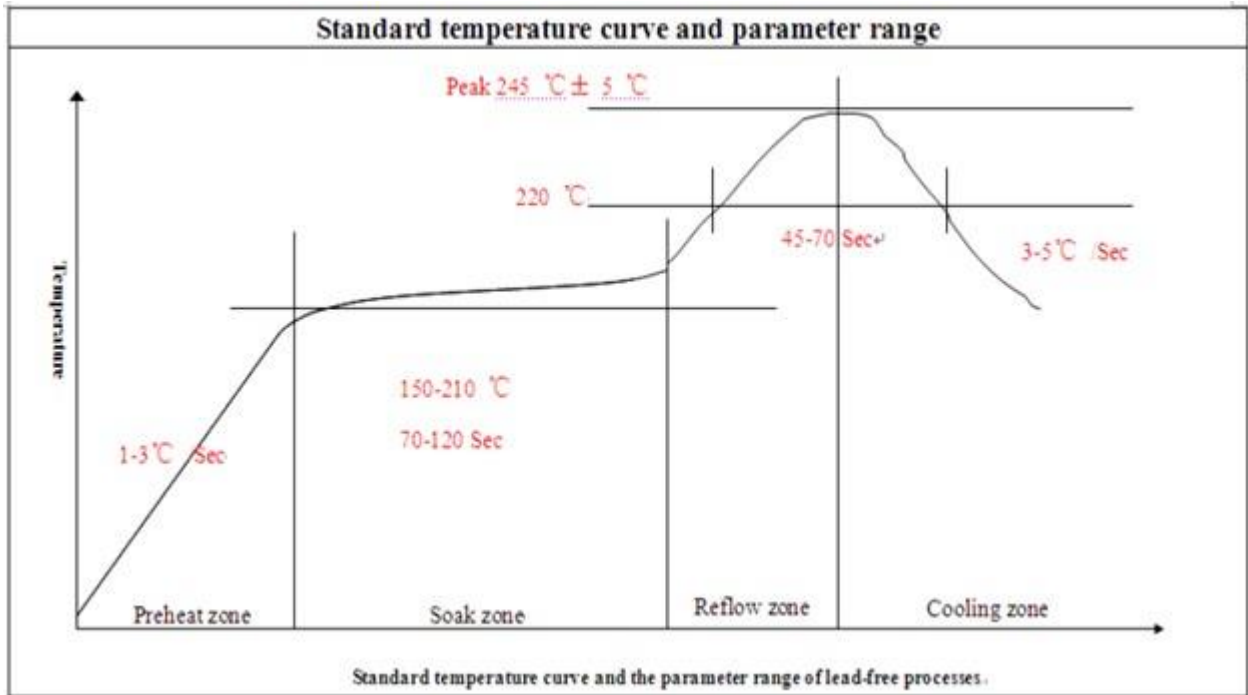

Figure 10 The Ramp-Soak-Spike reflow profile of CG37

CG37 is Moisture Sensitive Devices (MSD), appropriate MSD handling instruction and precautions are summarized in Chapter 6.3.

CG37 modules are also Electrostatic Sensitive Devices (ESD), handling CG37 modules without proper ESD protection may destroy or damage them permanently. Avoid ultrasonic exposure due to internal crystal and SAW components.

6.3 Moisture sensitivity

CG37 module is moisture sensitive at MSL 3, dry packed according to IPC/JEDEC specification J-STD-020C. The calculated shelf life for dry packed SMD packages is a minimum of 6 months from the bag seal date, when stored in a non-condensing atmospheric environment of <40°C/90% RH.

Table 11 lists floor life for different MSL levels in the IPC/JDEC specification:

Table 11 Moisture Classification Level and Floor Life

Level	Floor Life(out of bag)at factory ambient $\leq +30^{\circ}\text{C}/60\%\text{RH}$ or as stated
1	Unlimited at $\leq +30^{\circ}\text{C}/85\% \text{ RH}$
2	1 year
2a	4 weeks
3	168 hours
4	72 hours
5	48 hours
5a	24 hours
6	Mandatory bake before use. After bake, module must be reflowed within the time limit specified on the label.

Factory floor life is 1 week for MSL 3. CG37 must be processed and soldered within the time. If this time is exceeded, the devices need to be pre-baked before the reflow solder process.

Both encapsulate and substrate materials absorb moisture. IPC/JEDEC specification J-STD-020 must be observed to prevent cracking and delamination associated with the "popcorn" effect during reflow soldering. The popcorn effect can be described as miniature explosions of evaporating moisture. Baking before processing is required in the following case:

Floor life or environmental requirements after opening the seal have been exceeded, e.g. exposure to excessive seasonal humidity.

Refer to Section 4 of IPC/JEDEC J-STD-033 for recommended baking procedures.

6.4 ESD handling precautions

CG37 modules are Electrostatic Sensitive Devices (ESD). Observe precautions for handling! Failure to observe these precautions can result in severe damage to the GNSS receiver!



GNSS receivers are Electrostatic Sensitive Devices (ESD) and require special precautions when

handling. Particular care must be exercised when handling patch antennas, due to the risk of electrostatic charges. In addition to standard ESD safety practices, the following measures should be taken into account whenever handling the receiver:

Unless there is a galvanic coupling between the local GND (i.e. the work Table) and the PCB GND, then the first point of contact when handling the PCB shall always be between the local GND and PCB GND. Before mounting an antenna patch, connect ground of the device

When handling the RF pin, do not come into contact with any charged capacitors and be careful when contacting materials that can develop charges (e.g. patch antenna ~10pF, coax cable ~50-80pF/m, soldering iron). To prevent electrostatic discharge through the RF input, do not touch the mounted patch antenna.

When soldering RF connectors and patch antennas to the receiver's RF pin, the user must make sure to use an ESD safe soldering iron (tip).

6.5 Shipment

CG37 is designed and packaged to be processed in an automatic assembly line, and it is now packaged tray and reel.

7. Reference Design

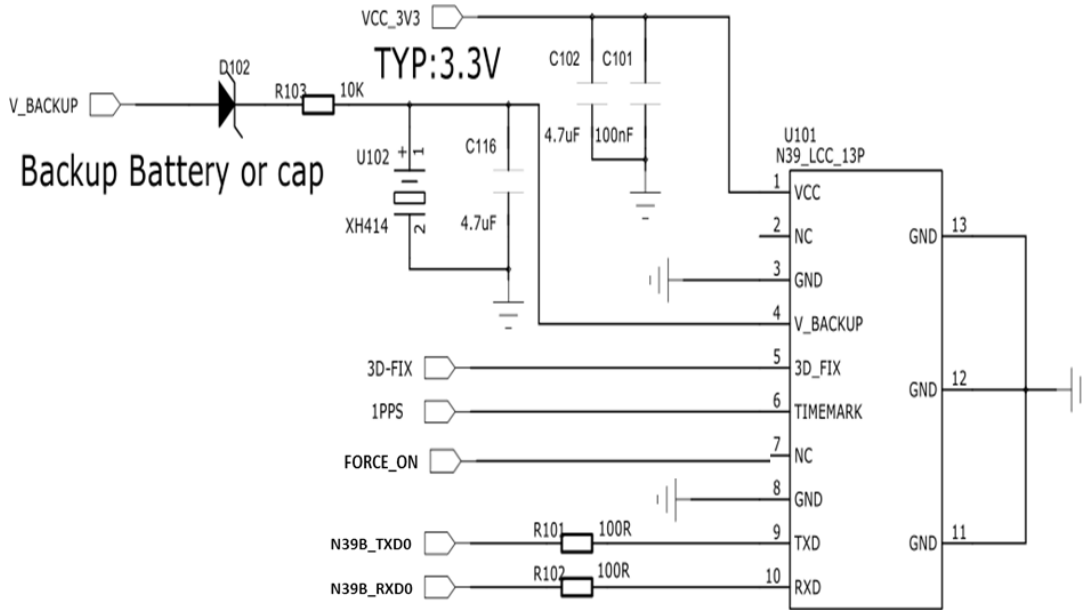

Figure 11 Application schematics

Appendix

A. Related Documents

Table 12 Related documents

SN	Document name	Remark
[1]	MT3333 Platform NMEA Message Specification	
[2]	EPO-II Format Protocol Customer	EPO-II Format and Protocol

B. Terms and Abbreviations

Abbreviation	Description
A-GPS	Assisted Global Positioning System
CMOS	Complementary Metal Oxide Semiconductor
CEP	Circular Error Probable
DGPS	Difference Global Positioning System
EEPROM	Electrically Erasable Programmable Read Only Memory
EPO	Extended Prediction Orbit
ESD	Electrostatic Sensitive Devices
EASY	Embedded Assist System
EGNOS	European Geostationary Navigation Overlay Service
GPS	Global Positioning System
GAGAN	The GPS Aided Geo Augmented Navigation
I/O	Input/Output
IC	Integrated Circuit
Inorm	Normal Current
Imax	Maximum Load Current

kbps	Kilobits per second
MSL	moisture sensitive level
MSAS	Multi-Functional Satellite Augmentation System
NMEA	National Marine Electronics Association
PRN	Pseudo Random Noise Code
QZSS	Quasi-Zenith Satellites System
SBAS	Satellite Based Augmentation Systems
WAAS	Wide Area Augmentation System